

Copyright Reserved
The Contractor shall verify and be responsible for all dimensions. DO NOT scale the drawing. Any errors or omissions shall be reported to Stantec without delay. The Copyrights to all designs and drawings are the property of Stantec. Reproduction or use for any purpose other than that authorised by Stantec is forbidden.

- Notes**
- UTILITIES NOTE: The position of any existing public or private sewers, utility services, plant or apparatus shown on this drawing is believed to be correct, but no warranty to this is expressed or implied. Other such plant or apparatus may also be present but not shown. The Contractor is therefore advised to undertake their own investigation where the presence of any existing sewers, services, plant or apparatus may affect their operations.
- DO NOT SCALE THIS DRAWING. IF IN DOUBT REQUEST FURTHER INFORMATION.
 - THIS DRAWING IS NOT TO BE USED FOR APPROVAL OR CONSTRUCTION AND AT THIS STAGE IS **CONCEPT ONLY**, SUBJECT TO DETAILED DESIGN INCLUDING TOPO SURVEY.
 - VEHICLE TRACKING MODELED AT A FORWARD DESIGN SPEED OF 5 KM/H.
 - VEHICLE TRACKING AND VISIBILITY IS BASED ON MAXIMUM LEGAL VEHICLE SIZE, THROUGH DETAILED DESIGN AND VEHICLE SELECTION THE REQUIREMENTS FOR HEDGE REMOVAL AND EXTENT OF HARD SURFACING WHERE PRACTICAL MAY BE REDUCED.
 - VEHICLES EXPECTED TO TRAVEL TO / FROM ACCESS A49 VIA A140 IPSWICH ROAD / CARGATE LANE / THE STREET / THE GREEN / FYLANDS ROAD / WASH LANE / MARKET LANE.
 - PHASE USE OF ACCESS A49 - CONSTRUCTION & OPERATION. A49 HIGHWAY ACCESS TO PROVIDE ACCESS TO 8A.

LEGEND

	PUBLIC RIGHT OF WAY (PROW)
	ORDER LIMIT
	2.4 x 70m VISIBILITY SPLAY
	VISIBILITY ADDITIONAL AREA

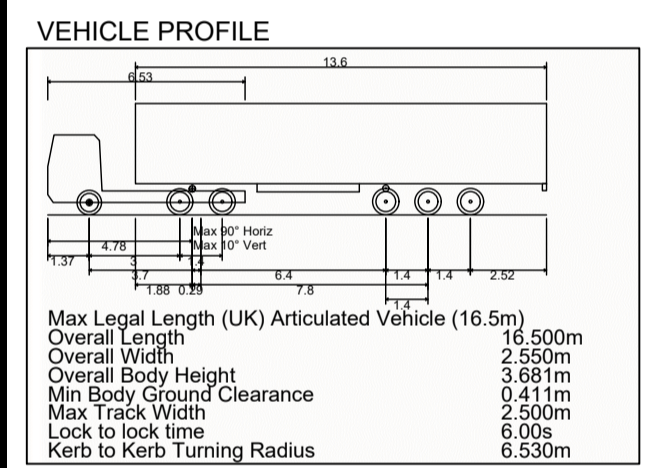

P01	FIRST ISSUE	JO	TH	2024.02.11
Issued/Revision		By	Appd	YYYY.MM.DD
		KWM	KWM	JO
		Dwn.	Dsgn.	Chkd.
				2025.12.09
				YYYY.MM.DD

Issue Status
S2 - FOR INFORMATION

This document is suitable only for the purpose noted above. Use of this document for any other purpose is not permitted.

Client/Project Logo



Client/Project
ISLAND GREEN POWER
EAST PYE SOLAR FARM
DEVELOPMENT CONSENT ORDER

Title
INDICATIVE SITE ACCESS A49
MARKET LANE
16.5m HGV
SHEET 8

Project No.	333101678	A1 Scale	AS SHOWN
Revision	P01	Drawing No.	333101678-STN-HGN-XX-DR-TR-5500

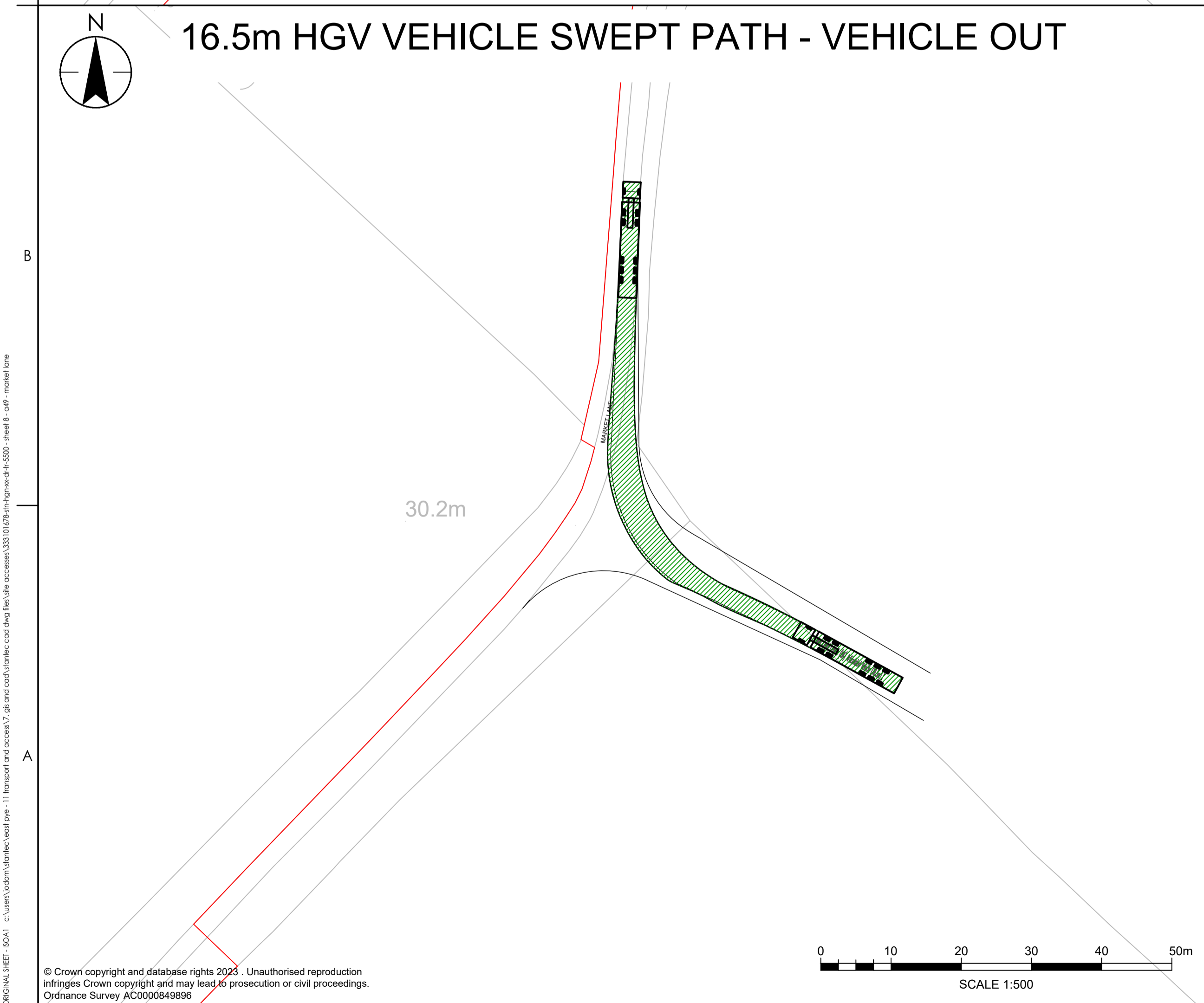
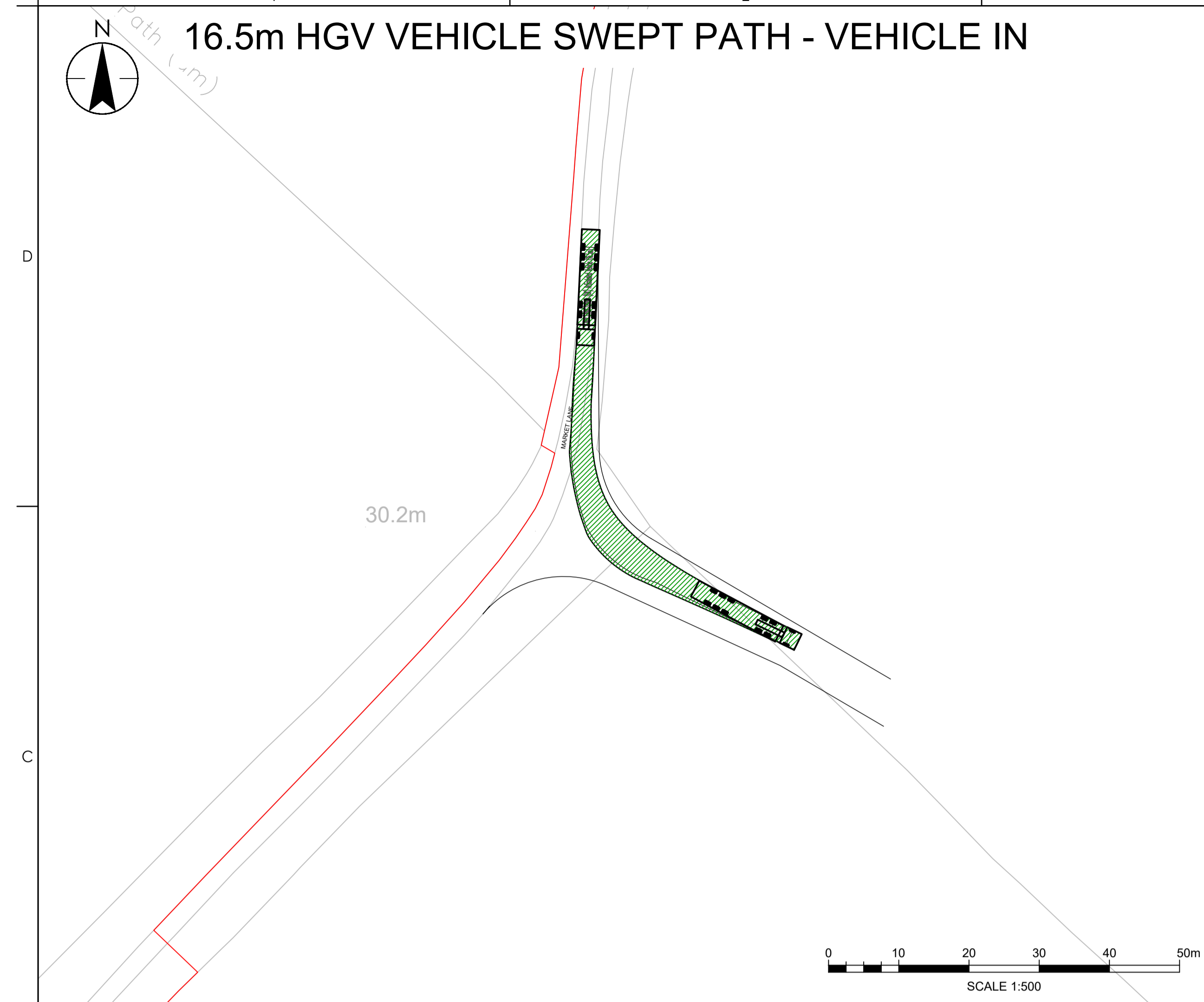
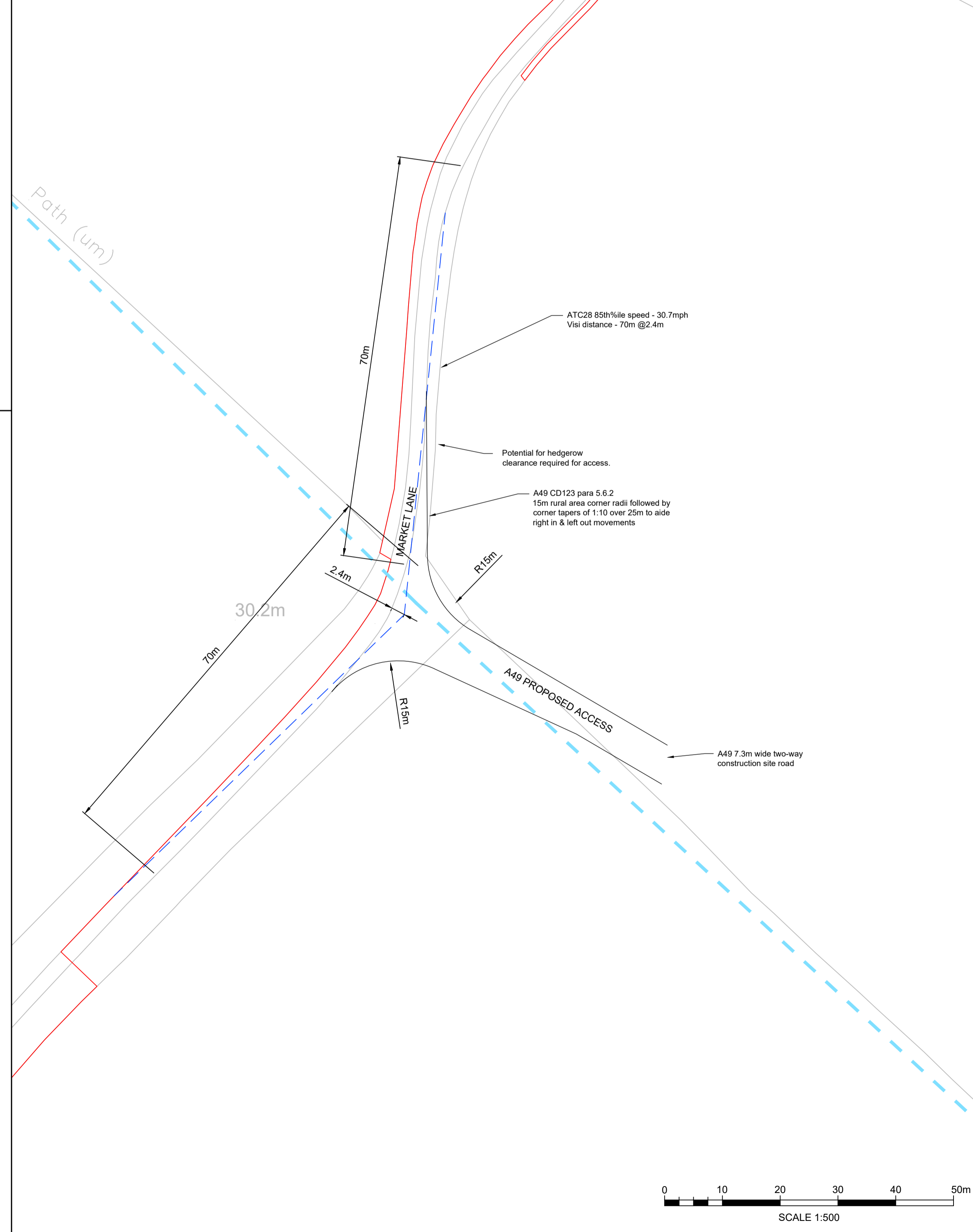
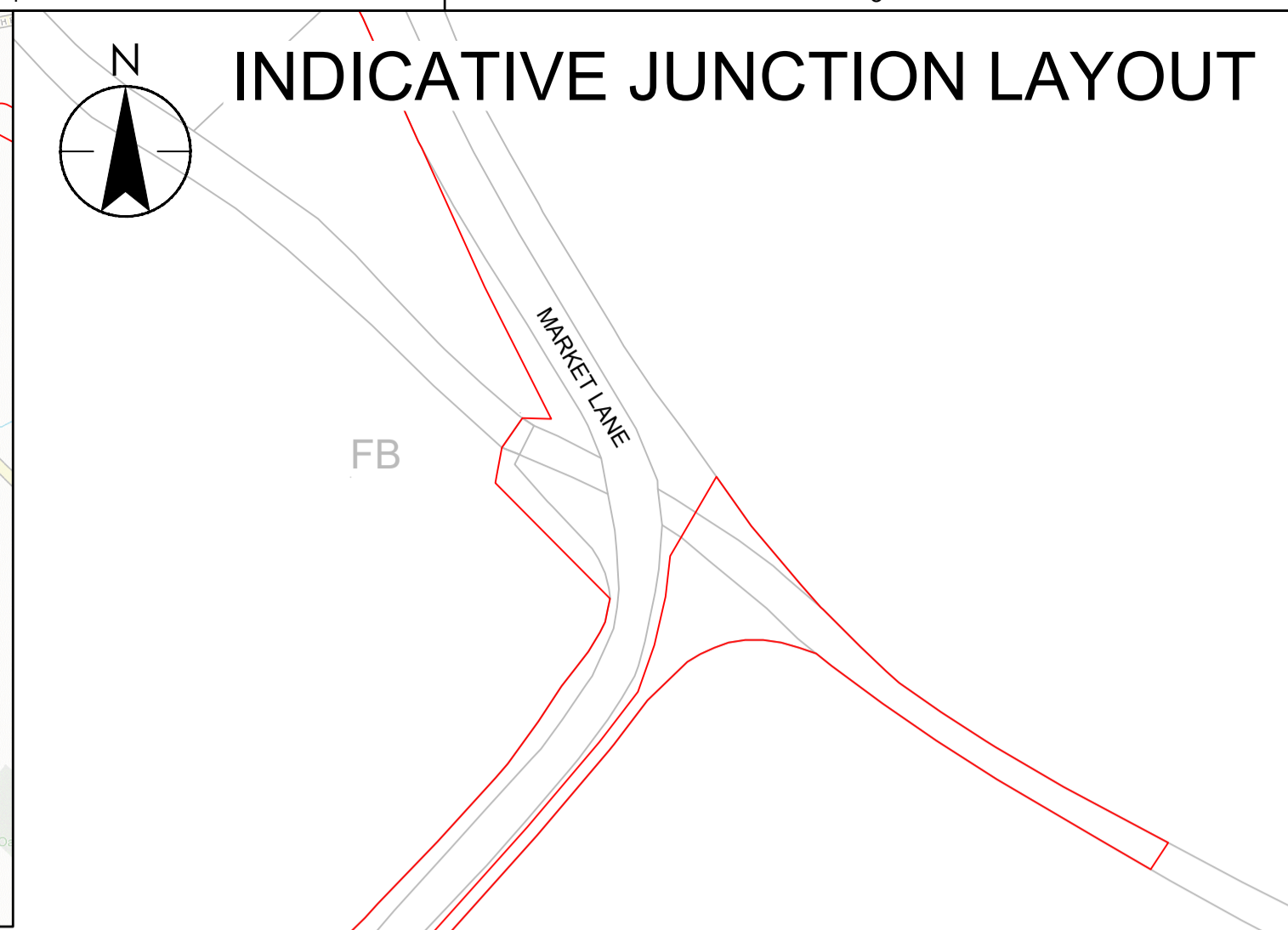
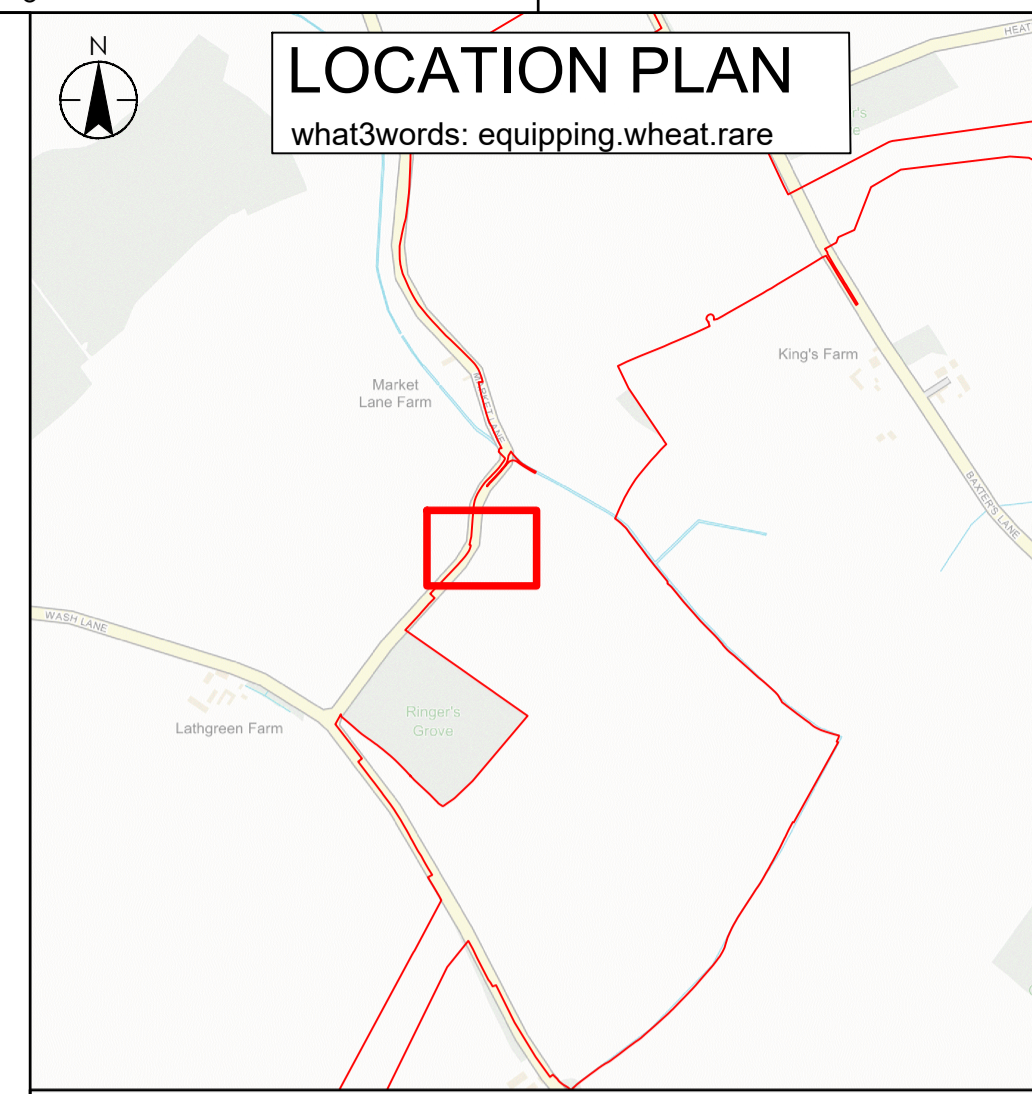

© Crown copyright and database rights 2023. Unauthorised reproduction infringes Crown copyright and may lead to prosecution or civil proceedings. Ordnance Survey AC0000649896

Copyright Reserved
The Contractor shall verify and be responsible for all dimensions, DO NOT scale the drawing. Any errors or omissions shall be reported to Stantec without delay. The Copyrights to all designs and drawings are the property of Stantec. Reproduction or use for any purpose other than that authorised by Stantec is forbidden.

- Notes
- UTILITIES NOTE: The position of any existing public or private sewers, utility services, plant or apparatus shown on this drawing is believed to be correct, but no warranty to this is expressed or implied. Other such plant or apparatus may also be present but not shown. The Contractor is therefore advised to undertake their own investigation where the presence of any existing sewers, services, plant or apparatus may affect their operations.
- DO NOT SCALE THIS DRAWING. IF IN DOUBT REQUEST FURTHER INFORMATION.
 - THIS DRAWING IS NOT TO BE USED FOR APPROVAL OR CONSTRUCTION AND AT THIS STAGE IS **CONCEPT ONLY**, SUBJECT TO DETAILED DESIGN INCLUDING TOPO SURVEY.
 - VEHICLE TRACKING MODELED AT A FORWARD DESIGN SPEED OF 5 KM/H.
 - VEHICLE TRACKING AND VISIBILITY IS BASED ON MAXIMUM LEGAL VEHICLE SIZE THROUGH DETAILED DESIGN AND VEHICLE SELECTION THE REQUIREMENTS FOR HEDGE REMOVAL AND EXTENT OF HARD SURFACING WHERE PRACTICAL MAY BE REDUCED.
 - PHASE USE OF CROSSING A47 - CONSTRUCTION.

- LEGEND
- PUBLIC RIGHT OF WAY (PROW)
 - ORDER LIMIT
 - 2.4 x 90m VISIBILITY SPLAY
 - VISIBILITY ADDITIONAL AREA

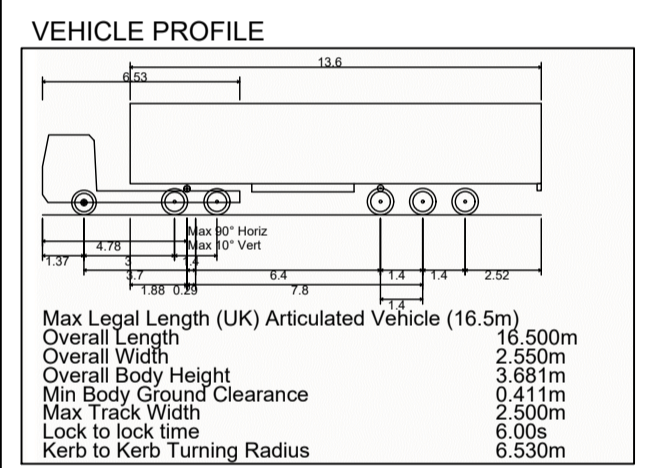

PD1 - FIRST ISSUE	JO	TH	2024.02.11
Issued/Revision	By	Appd	YYYY.MM.DD
	KWM	KWM	JO
	Dwn.	Dsgn.	Chkd.
			2025.12.09
			YYYY.MM.DD

Issue Status
S2 - FOR INFORMATION

This document is suitable only for the purpose noted above. Use of this document for any other purpose is not permitted.

Client/Project Logo



Client/Project
ISLAND GREEN POWER
EAST PYE SOLAR FARM
DEVELOPMENT CONSENT ORDER

Title
INDICATIVE SITE CROSSING ACCESS A47
WASH LANE
16.5m HGV
SHEET 11

Project No. 333101678 A1 Scale AS SHOWN
Revision P01 Drawing No. 333101678-STN-HGN-XX-DR-TR-5500

16.5m HGV VEHICLE SWEEP PATH - NORTHEAST BOUND

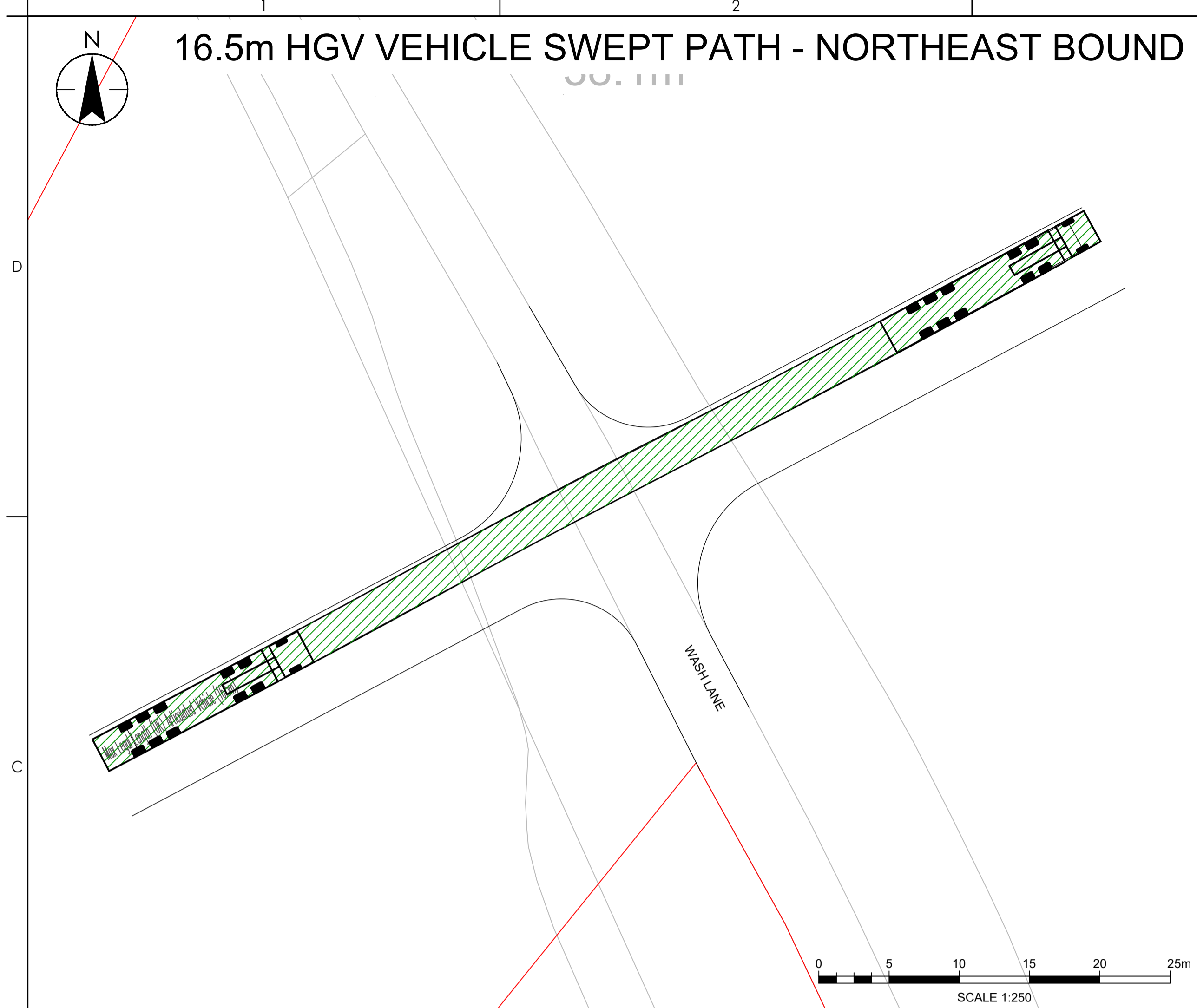

LOCATION PLAN

what3words: lots.crinkled.farmed

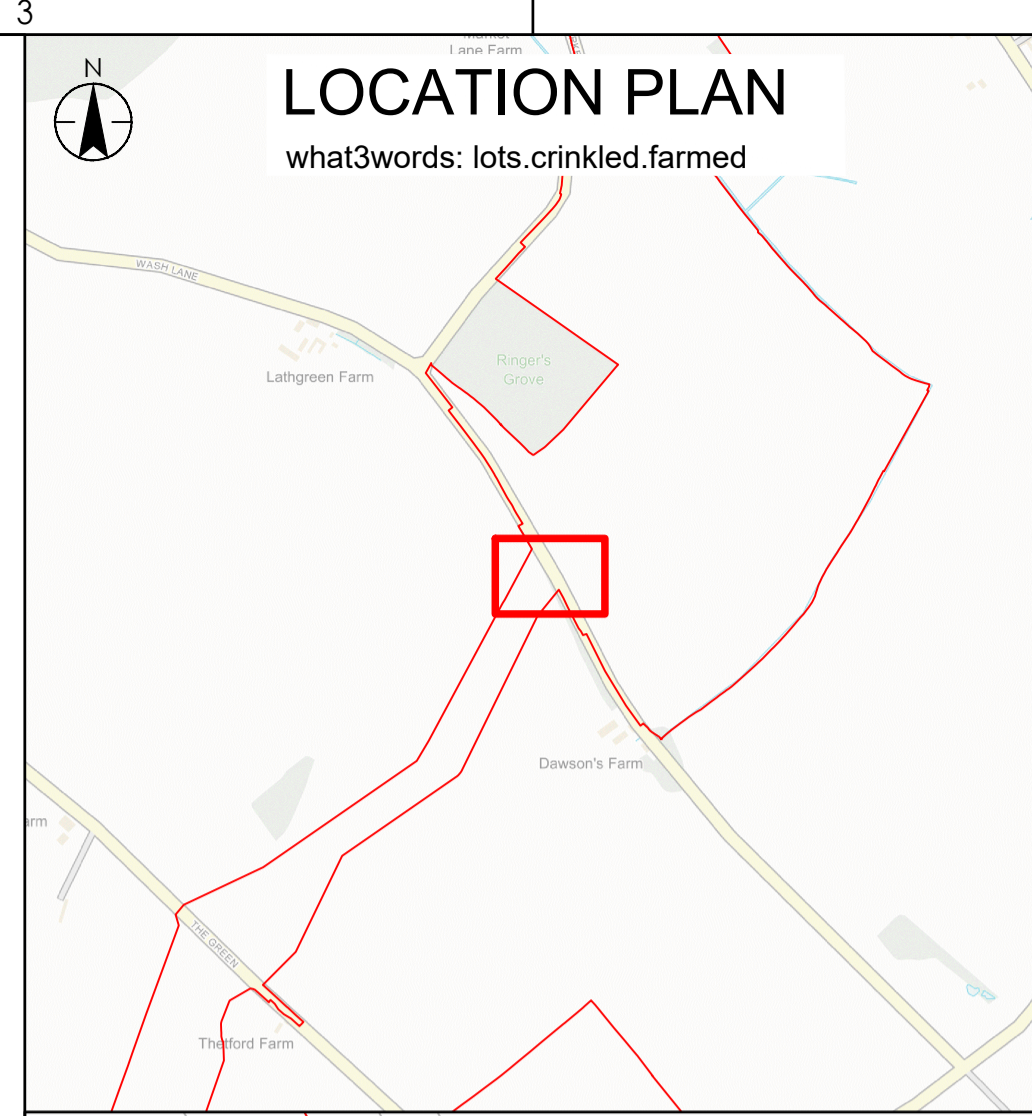

INDICATIVE JUNCTION LAYOUT

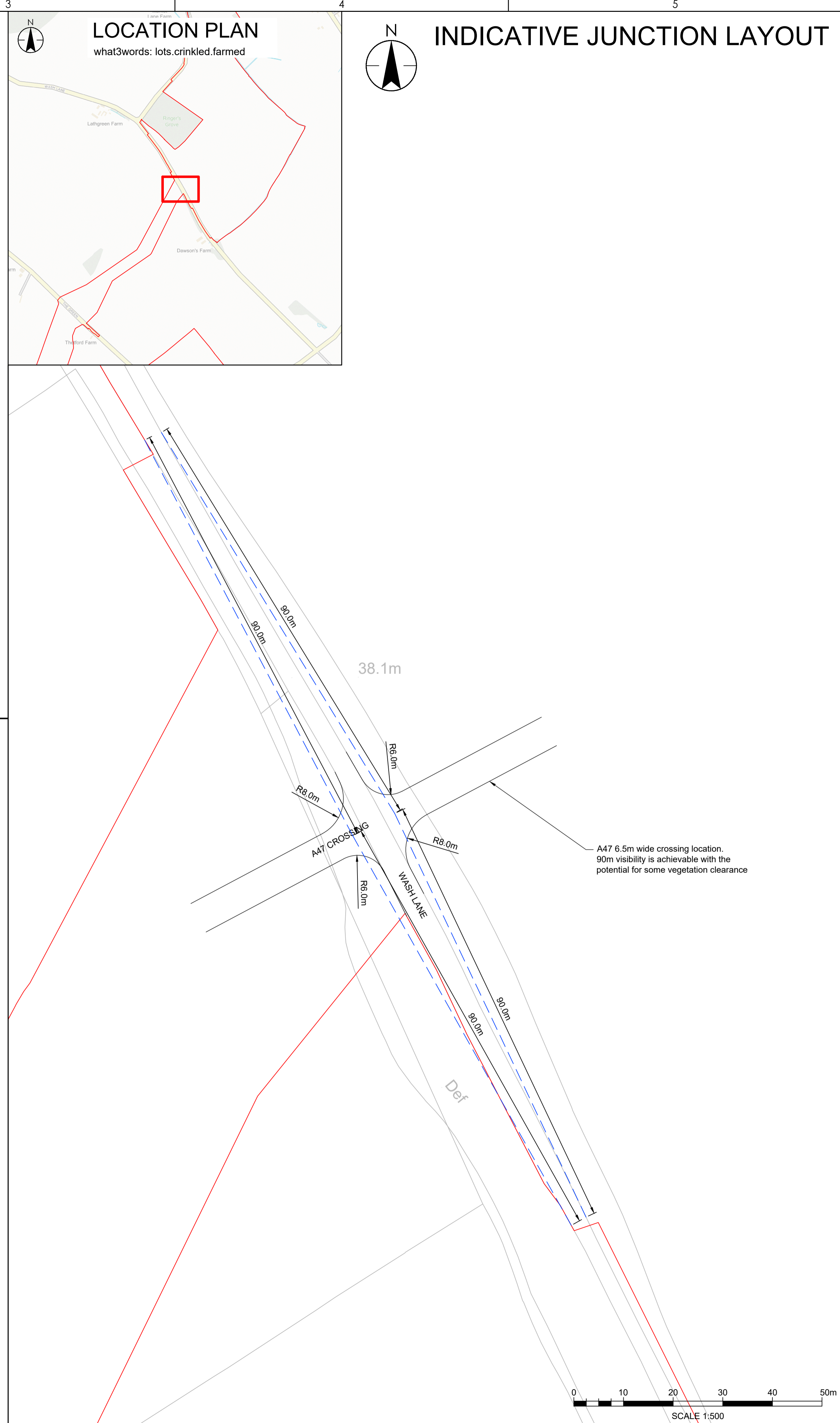

16.5m HGV VEHICLE SWEEP PATH - SOUTHWEST BOUND

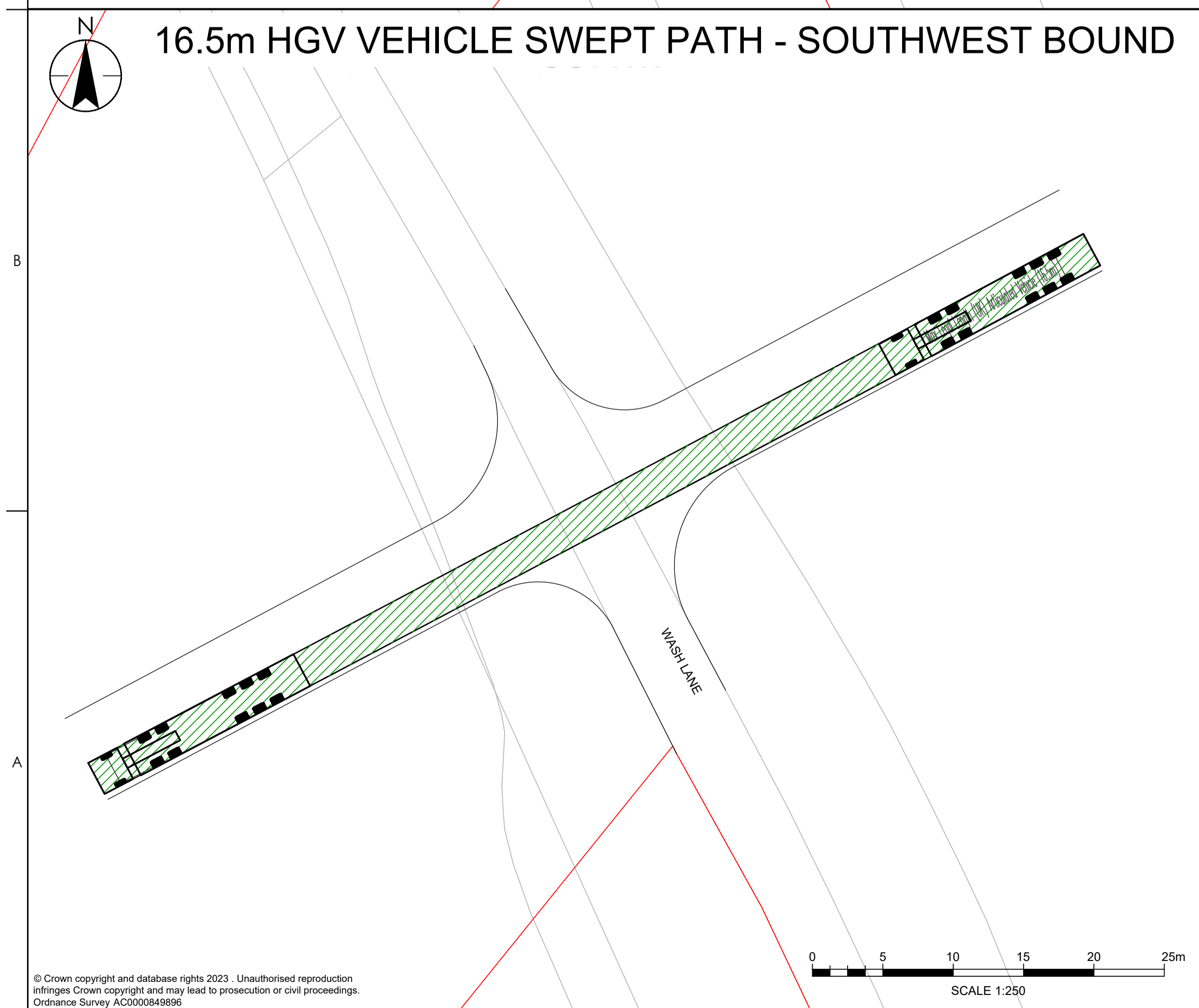

File: C:\projects\333101678\333101678-01-INDICATIVE SITE CROSSING ACCESS A47\Drawings\11-01-INDICATIVE SITE CROSSING ACCESS A47\11-01-INDICATIVE SITE CROSSING ACCESS A47.dwg
 Project: 333101678-01-INDICATIVE SITE CROSSING ACCESS A47
 Date: 2024-02-11
 User: jthomas
 Plot: 11-01-INDICATIVE SITE CROSSING ACCESS A47.dwg
 Scale: 1:250
 Sheet: 11 of 11
 Title: INDICATIVE SITE CROSSING ACCESS A47 WASH LANE 16.5m HGV SHEET 11

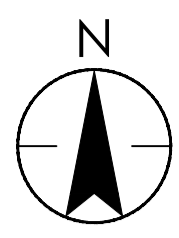

INDICATIVE JUNCTION LAYOUT

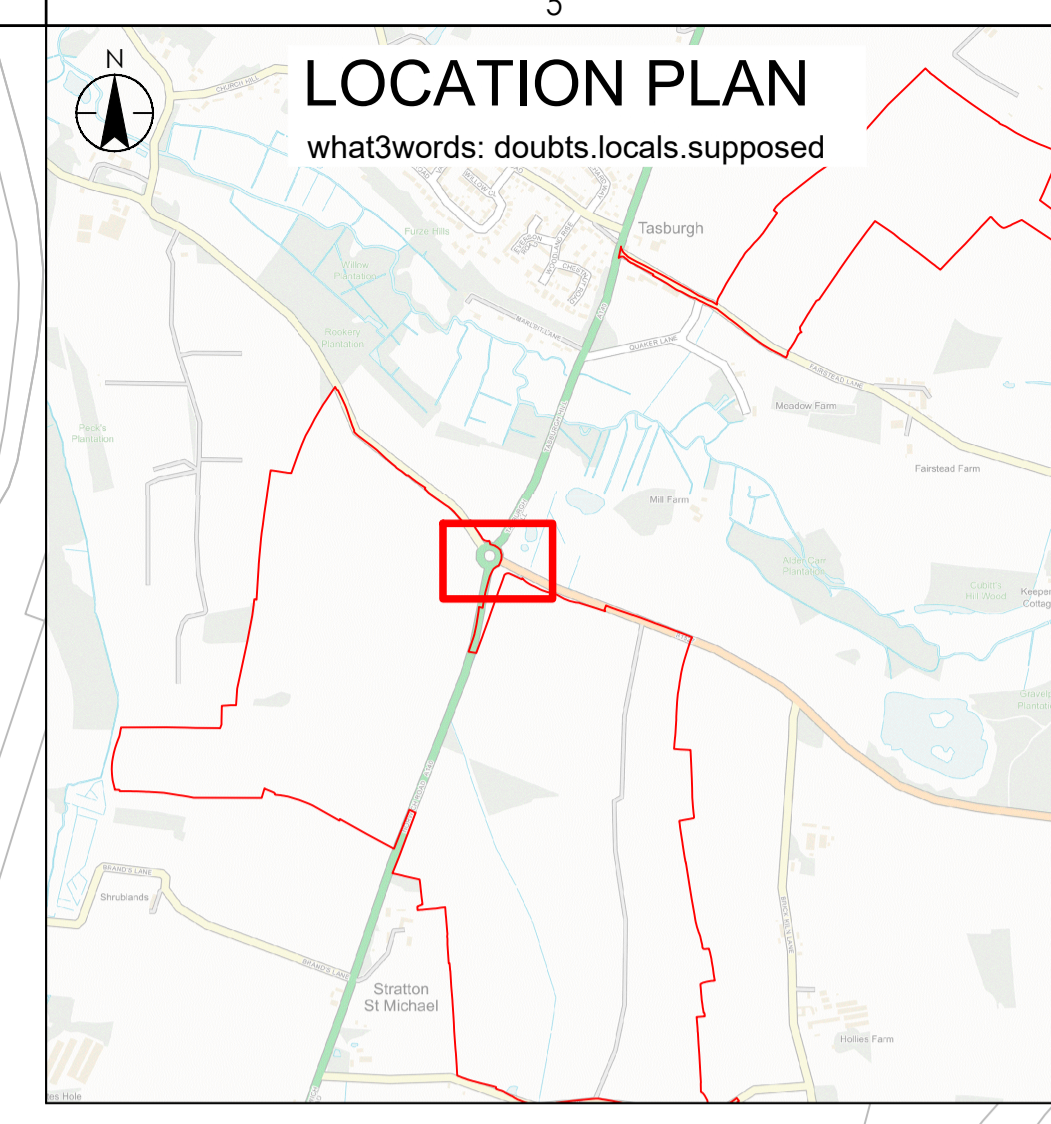

Stantec UK Limited
The Stills, 1st Floor, 80 Tummill Street
London
EC1M 5QU
Tel. +44 20 3824 6600
www.stantec.com/uk

Copyright Reserved
The Contractor shall verify and be responsible for all dimensions. DO NOT scale the drawing. Any errors or omissions shall be reported to Stantec without delay. The Copyrights to all designs and drawings are the property of Stantec. Reproduction or use for any purpose other than that authorised by Stantec is forbidden.

- Notes**
- UTILITIES NOTE: The position of any existing public or private sewers, utility services, plant or apparatus shown on this drawing is believed to be correct, but no warranty to this is expressed or implied. Other such plant or apparatus may also be present but not shown. The Contractor is therefore advised to undertake their own investigation where the presence of any existing sewers, services, plant or apparatus may affect their operations.
 - DO NOT SCALE THIS DRAWING. IF IN DOUBT REQUEST FURTHER INFORMATION.
 - THIS DRAWING IS NOT TO BE USED FOR APPROVAL OR CONSTRUCTION AND AT THIS STAGE IS CONCEPT ONLY, SUBJECT TO DETAILED DESIGN INCLUDING TOPO SURVEY.
 - VEHICLE TRACKING MODELED AT A FORWARD DESIGN SPEED OF 5 KM/H.
 - VEHICLE TRACKING AND VISIBILITY IS BASED ON MAXIMUM LEGAL VEHICLE SIZE, THROUGH DETAILED DESIGN AND VEHICLE SELECTION THE REQUIREMENTS FOR HEDGE REMOVAL AND EXTENT OF HARD SURFACING WHERE PRACTICAL MAY BE REDUCED.
 - VEHICLES EXPECTED TO TRAVEL TO / FROM ACCESS A19 VIA A140 NORWICH ROAD.
 - PHASE USE OF ACCESS A19 - CONSTRUCTION AND OPERATION. A19 HIGHWAY ACCESS TO PROVIDE ACCESS TO 4A.

A19 access uses previously constructed but unused roundabout arm. Curvature of arm only allows for single vehicle ingress/egress. Visibility has not been checked at this stage.

A19 PROPOSED ACCESS

B1527

Balancing Ponds

A140 IPSWICH ROAD

B 1527

El Sub Sta

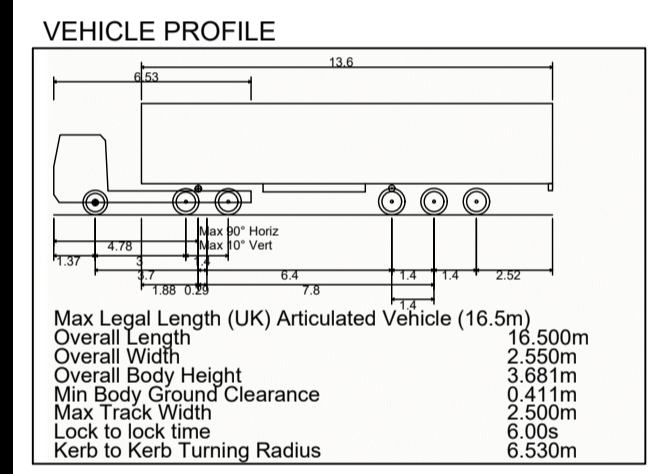
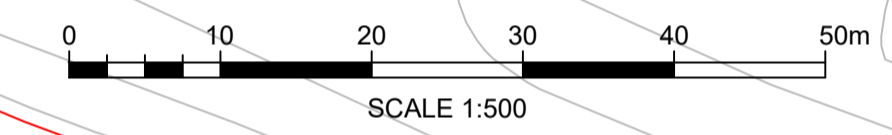

PO1	FIRST ISSUE	JO	TH	2024.02.11
	Issued/Revision	By	Appd	YYYY.MM.DD
		KWM	KWM	JO
		Dwn.	Dsgn.	Chkd.
				2025.12.09
				YYYY.MM.DD

Issue Status

S2 - FOR INFORMATION

This document is suitable only for the purpose noted above. Use of this document for any other purpose is not permitted.



Client/Project
ISLAND GREEN POWER
EAST PYE SOLAR FARM
DEVELOPMENT CONSENT ORDER

Title
INDICATIVE SITE ACCESS A19
CHURCH LANE
16.5m HGV
SHEET 32

Project No. 333101678 A1 Scale AS SHOWN
Revision P01 Drawing No. 333101678-STN-HGN-XX-DR-TR-5500

16.5m HGV VEHICLE SWEEP PATH - INBOUND

16.5m HGV VEHICLE SWEEP PATH - OUTBOUND

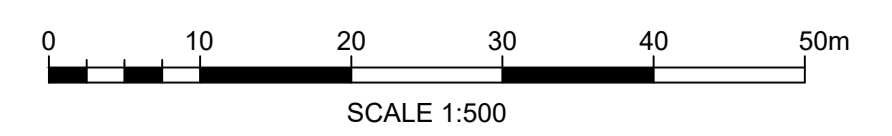
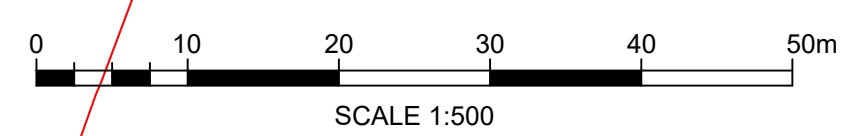
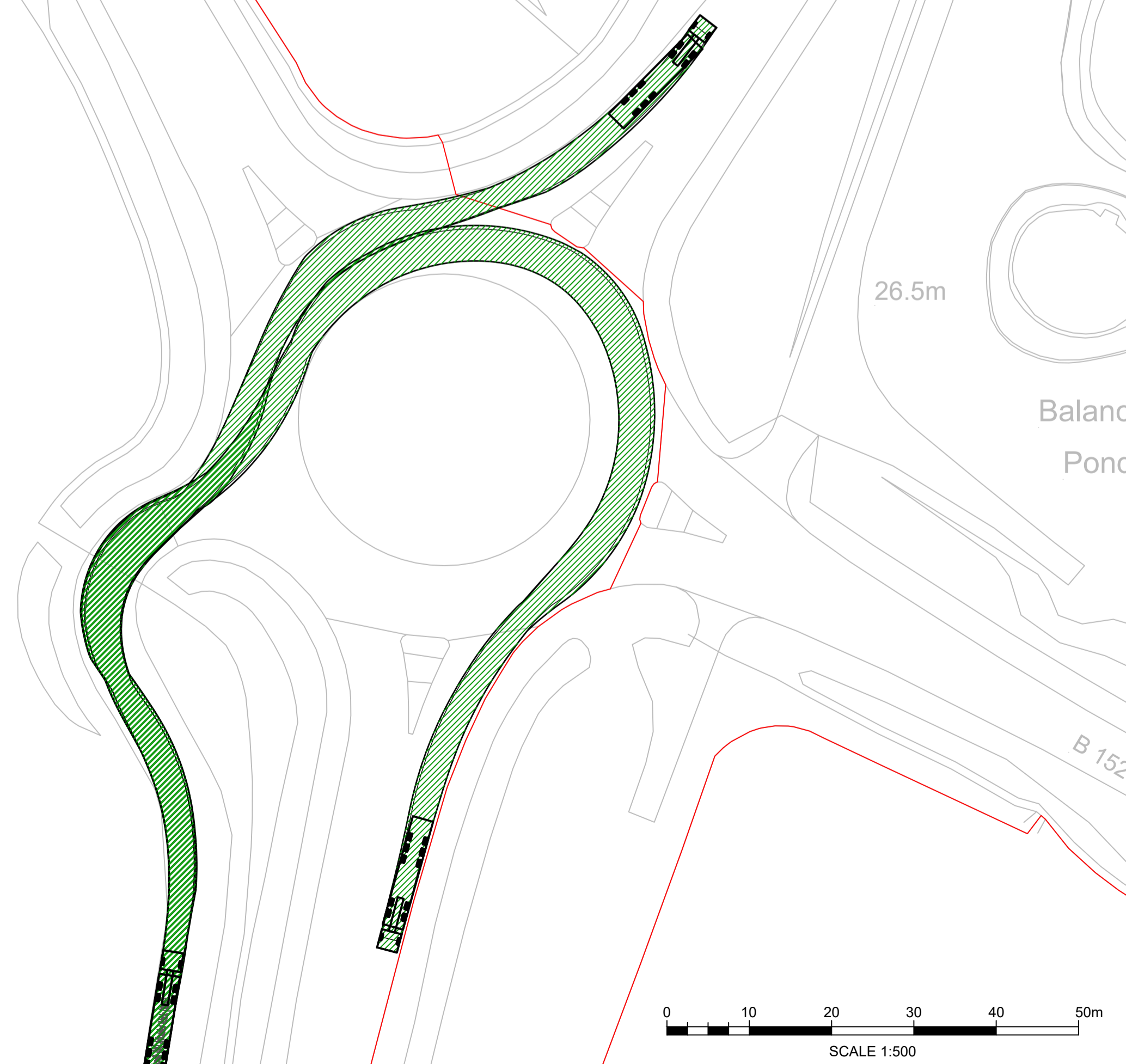
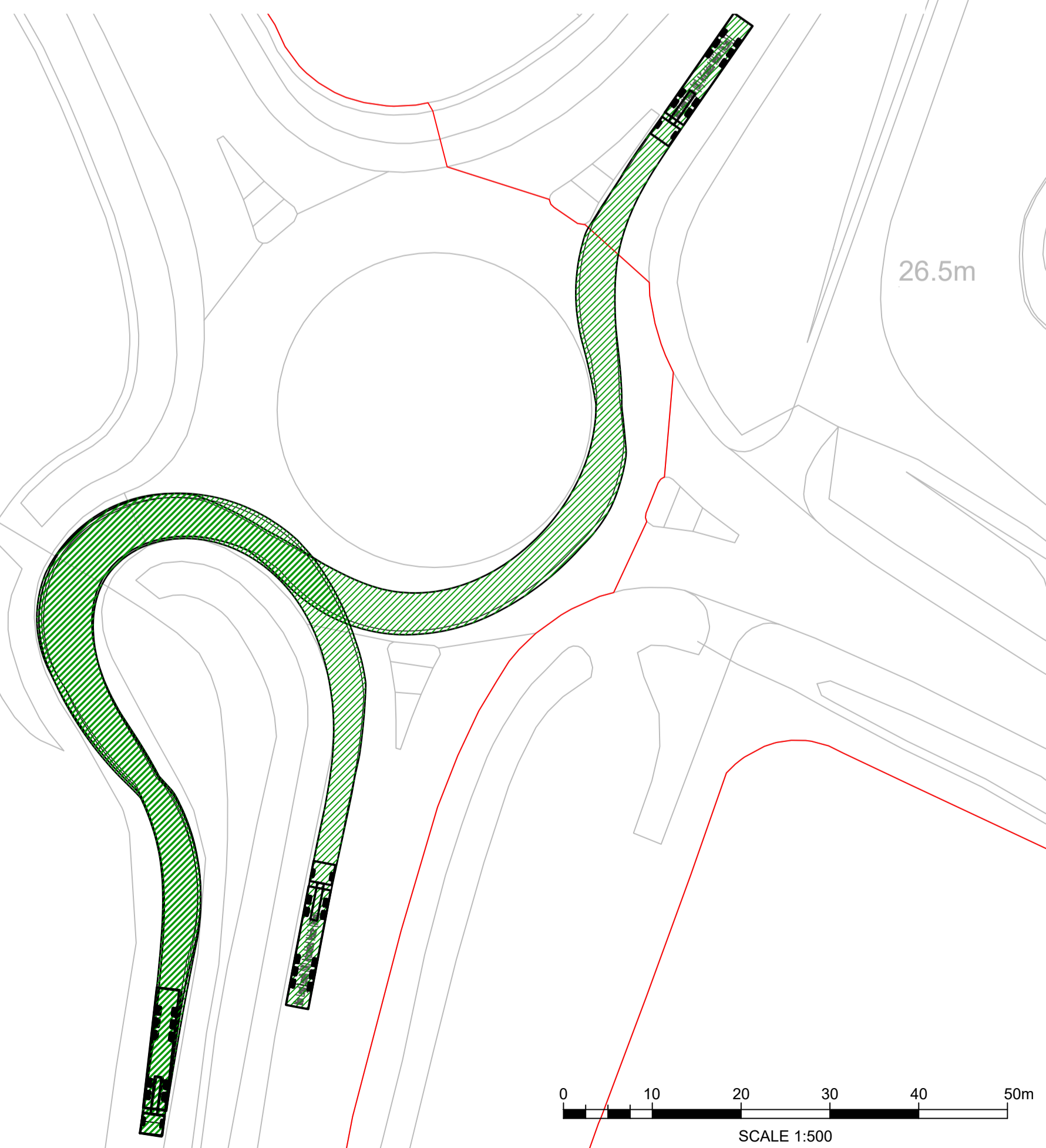
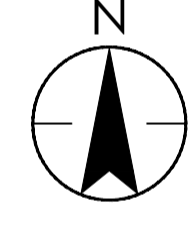
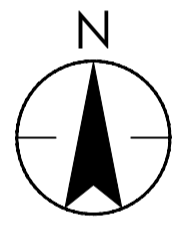

P:\0316\333101678\333101678-INDICATIVE SITE ACCESS A19.dwg (16.5m HGV) - 11/10/2024 10:00:00 AM - 1:1:11 PM - 1:1:11 PM - 1:1:11 PM
 P:\0316\333101678\333101678-INDICATIVE SITE ACCESS A19.dwg (16.5m HGV) - 11/10/2024 10:00:00 AM - 1:1:11 PM - 1:1:11 PM - 1:1:11 PM
 P:\0316\333101678\333101678-INDICATIVE SITE ACCESS A19.dwg (16.5m HGV) - 11/10/2024 10:00:00 AM - 1:1:11 PM - 1:1:11 PM - 1:1:11 PM
 P:\0316\333101678\333101678-INDICATIVE SITE ACCESS A19.dwg (16.5m HGV) - 11/10/2024 10:00:00 AM - 1:1:11 PM - 1:1:11 PM - 1:1:11 PM

© Crown copyright and database rights 2023. Unauthorised reproduction infringes Crown copyright and may lead to prosecution or civil proceedings. Ordnance Survey AC0000849896

